

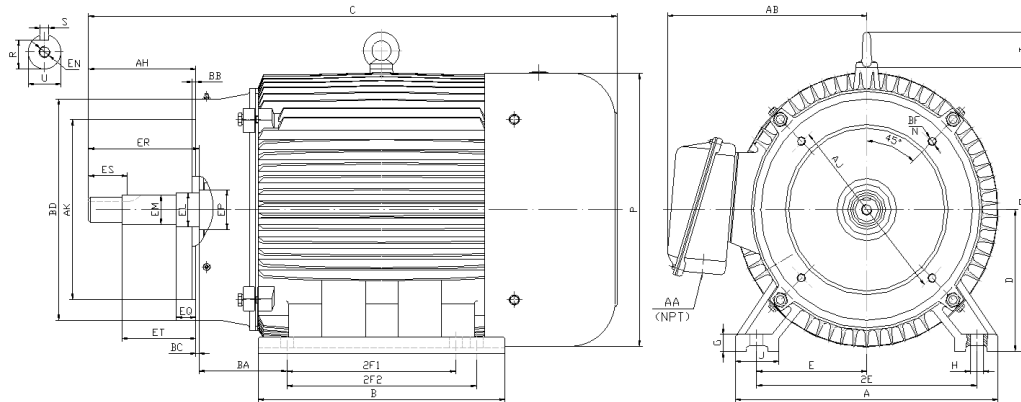

PE182JM-3-4

CLOSE COUPLED PUMP MOTORS
NEMA PREMIUM EFFICIENCY
TOTALLY ENCLOSED FAN COOLED, JM FRAME
INVERTER DUTY 10:1 CT; 20:1 VT - NEMA MG1 PART 31
Factory Certified for T2B Class I, Division II, Groups A,B,C & D and Class II, Division II, Groups F & G



DIMENSIONS

HP	RPM	Frame	MOUNTING														
			A	B	C	D	G	H	J	E	2E	2F1	2F2	O	P	T	BA
3	1800	182JM	9.5	7.3	18.48	4.5	0.6	0.41	2	3.75	7.5	4.5	5.5	9.1	8.7	1.6	3.5

FLANGE							Shaft Extension, Key Set										
AH	AJ	AK	BB	BC	BD	BF	U	R	S	EQ	ER	ES	ET	EP	EL	EM	EN
4.281	5.875	4.500	0.156	0.12	6.62	4*3/8-16	0.8745	0.771	0.190	0.640	4.25	1.65	2.890	1.57	1.250	1.0000	3/8-16
4.219		4.497	0.125				0.8740	0.756	0.188	0.610			2.860		1.248	0.9995	

Conduit Box		Bearings		Mount
AA	AB	DE	ODE	
0.75	7.5	6208-ZZ	6306-ZZ	F1

BEARING LUBRICATION: The bearings come lubricated with Mobil Polyrex EM Polyurea Grease.



Electrical Helper.org

For All Your Electric Needs Since 1928
 411 N Platte Ave. York, NE. 68467

AC-DC MOTORS :: SALES & SERVICE
REWINDING :: CUSTOM CONTROL PANEL

Kelly MacMillan
 Office Ph: 888-226-4917
 Fax: 888-226-4917
 Cell: 402-679-1579
 E-Mail: kelly@electricalhelper.com





PE182JM-3-4

CLOSE COUPLED PUMP MOTORS

NEMA PREMIUM EFFICIENCY

TOTALLY ENCLOSED FAN COOLED, JM FRAME

INVERTER DUTY 10:1 CT; 20:1 VT - NEMA MG1 PART 31

Factory Certified for T2B Class I, Division II, Groups A,B,C & D and Class II, Division II, Groups F & G

PERFORMANCE DATA

HP	RPM	Frame	Voltage	Frequency (Hz)	Full Load S.F.	Insulation Class	NEMA Design	Slip (%)	NEMA Code	Enclosure Type	IP Rating	Max. Ambient
3	1760	182JM	230/460	60	1.15	F	B	2.2	K	TEFC	55	40 °C

Amps (460V)		Efficiency (%)			Power Factor			Torque (ft-lb)			DE Bearing	ODE Bearing	Connection	Weight (lbs.)
FLA	LRA	100%	75%	50%	100%	75%	50%	FLT	LRT %	BDT %				
3.8	32	89.5	89.1	87.6	0.77	0.70	0.58	9	215	300	6208-ZZ	6306-ZZ	9 Lead 2Y/Y	89

*Usable at 208 Volts

NAME PLATE

		AC INDUCTION MOTOR INVERTER DUTY 20:1 VT; 10:1 CT								CONNECTION DIAGRAMS			
CAT NO. PE182JM-3-4		FRAME 182JM		PHASE 3		230V							
HZ 60	S.F. 1.15	HZ 50	S.F. 1.0	ENCL TEFC	IP 55	T4		T5		T6			
HP 3	RPM 1760	HP 3	RPM 1450	DUTY CONT	DES B	T7		T8		T9			
VOLTS 230/460		VOLTS 190/380		AMB 40 °C		INS F		T1		T2		T3	
AMPS 7.6/3.8		AMPS 9.8/4.9		DE BRG 6208-ZZ		L1		L2		L3			
CODE K	P.F. 0.77	CODE H	P.F. 0.80	ODE BRG 6306-ZZ									
EFF 89.5	MIN 87.5	EFF 87.0	MIN 85.0	LUB: Mobil Polyrex EM									
MOTOR WEIGHT 89 LBS		CONNECTION 9 Lead 2Y/Y		SER NO									
General purpose use on industrial machinery installed in damp, dusty or dirty environments. Hernando, Mississippi								CC082A		460V		T4 T5 T6 T7 T8 T9 T1 T2 T3 L1 L2 L3	

APPLICATIONS:

Specifically designed for use on industrial and commercial pumping units.



Electrical Helper.org

For All Your Electric Needs Since 1928
 411 N Platte Ave. York, NE. 68467

**AC-DC MOTORS :: SALES & SERVICE
 REWINDING :: CUSTOM CONTROL PANEL**

Kelly MacMillan
 Office Ph: 888-226-4917
 Fax: 888-226-4917
 Cell: 402-679-1579
 E-Mail: kelly@electricalhelper.com

