

## PEXP365TS-75-2

### Premium Efficiency Explosion Proof Motor

Class I, Division I, Groups C & D and Class II, Division II, Groups E, F and G - Operating Temperature Code: T3C

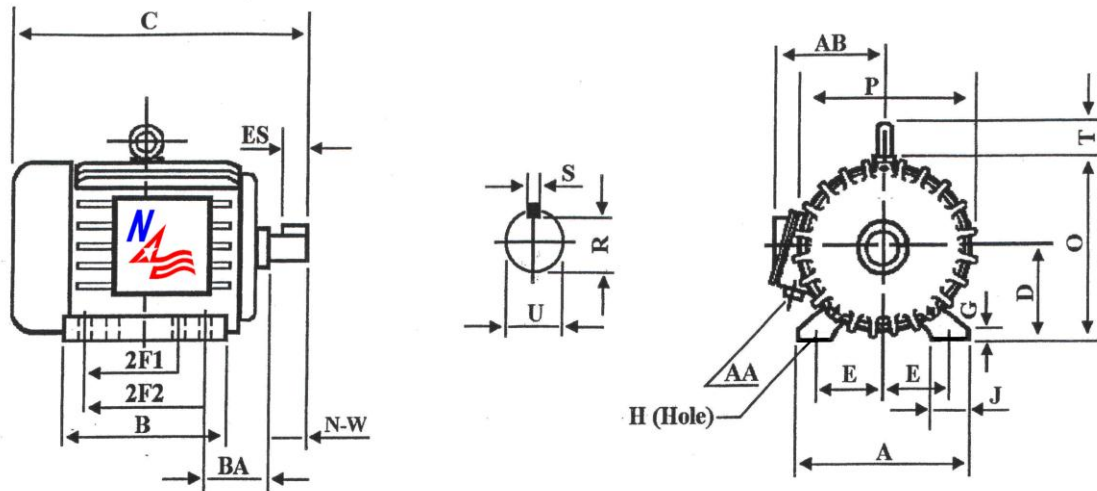

### DIMENSIONS – INCHES

A	B	C	D	E	2F1	2F2	G	H	J	O
18	16.2	33.3	9	14	11.25	12.25	1.1	0.7	3	19
P	R	S	T	U	ES	AA	AB	BA	N-W	Mount
19.5	1.591	0.5	2.5	1.875	2.03	3	16.5	5.88	3.75	F1

### PERFORMANCE DATA

Three Phase – 60Hz - 208-230/460V – NEMA Design B – Max. Ambient: 40° C

HP	Speed	Frame	NEMA Code	Efficiency (%)			Power Factor			Torque (ft-lb)		
				100%	75%	50%	100%	75%	50%	FLT	BDT	LRT
75	3573	365TS	G	93.6	94.3	93.9	88.0	88.4	84.1	110.9	200	105
Amps ( 460V)		DE Bearing	ODE Bearing	Insulation Class	Enclosure Type	Service Factor	Weight (lbs)					
FLA	LRA											
84.5	543	6313	6313	F	TEFC	1.15	946					



**ElectricalHelper**

"Practical Straight Forward Electrical Wiring Solutions Since 1928."

For Fast Friendly Assistance  
Call Us 888.226.4917  
Hours 8:00AM - 5:00PM